

# .357 AUTO MAG

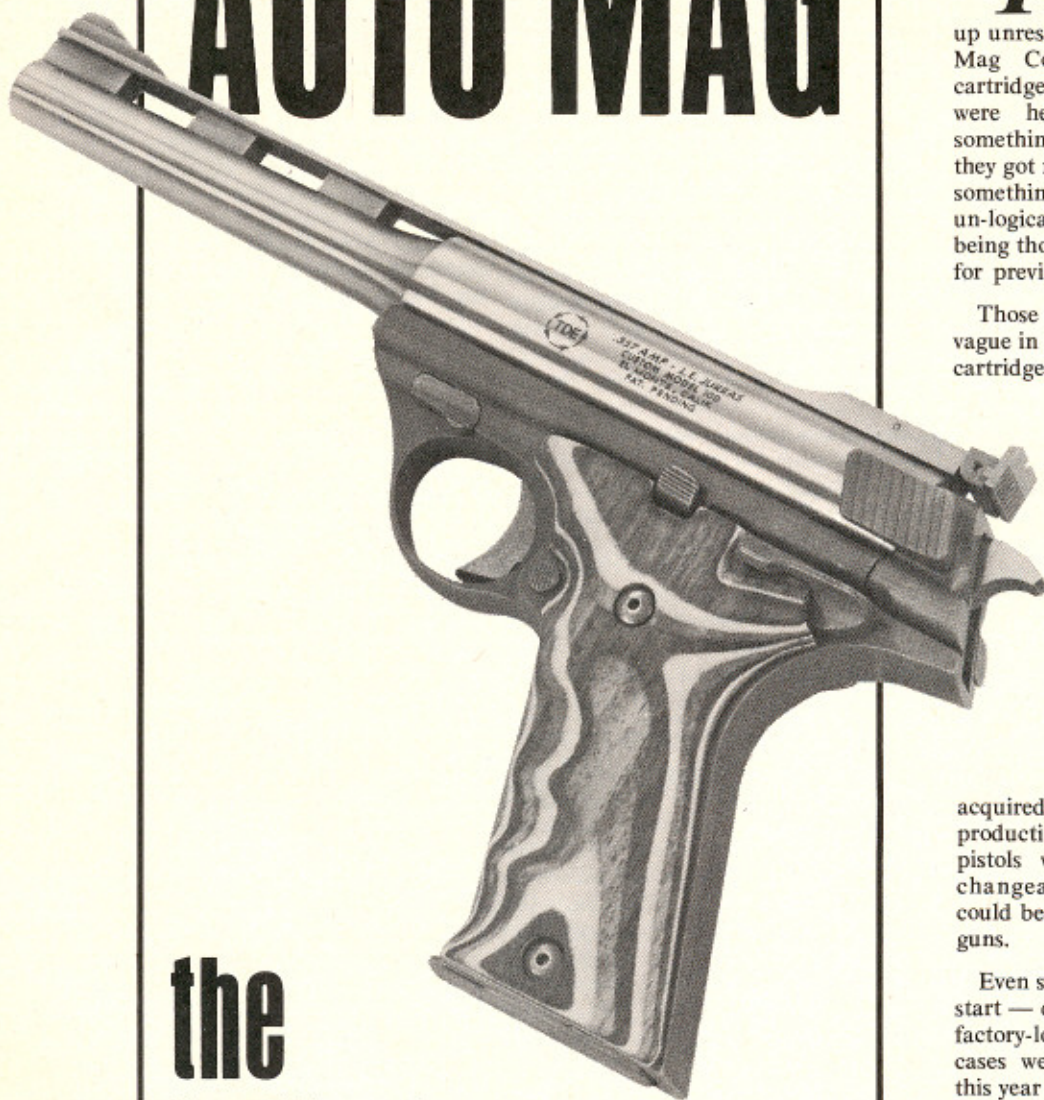

the  
hottest  
pistol  
of all

By GEORGE NONTE

**T**HE ORIGINAL .44 AMP pistol and cartridge were still stirring up unrest of various sorts when the Auto Mag Corporation announced a new cartridge. More than a few snide remarks were heard at the time, generally something like: "If they can't make what they got now, howinell they going to make something new." That wasn't an un-logical comment at the time, there being thousands of customers still waiting for previously ordered .44 Auto Mags.

Those earliest .357 AMP ads were a bit vague in that they didn't describe the new cartridge very well — some readers got the idea it was simply the .357 Magnum revolver cartridge. All that was cleared up, though, and the .357 AMP emerged as the .44 AMP case necked down to take nominal .355 to .357-inch diameter bullets. The highest velocity of any handgun cartridge was claimed, ranging upwards of 2,000 fps, depending on the bullet weight involved. It looked great.

Eventually, after T.D.E. acquired the Auto Mag assets and began production of the guns, some .357 AMP pistols were produced, as were interchangeable barrel assemblies, which could be installed upon existing .44 AMP guns.

Even so, the .357 AMP got off to a slow start — doubtless due to the fact that no factory-loaded ammunition or empty cases were available. However, earlier this year the .357 AMP got a considerable boost when Lee Jurras commissioned the building of 100 specially numbered and finished guns as the L.E.J. Model 100. This stirred up a lot of interest in the cartridge, as did the announcement that later this year Super Vel will produce

L.E. Jurras and Associates, Inc. of Shelbyville, Indiana, now has exclusive worldwide distribution rights to the Auto Mag Pistol. The suggested retail price is \$495 with either a 6½ or 8½-inch barrel, in .357 AMP or .44 AMP. The gun shown is one of 100 limited edition guns originally purchased by Jurras.

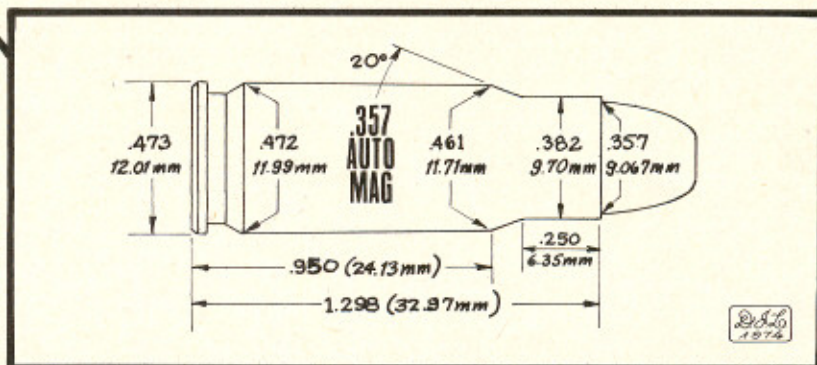
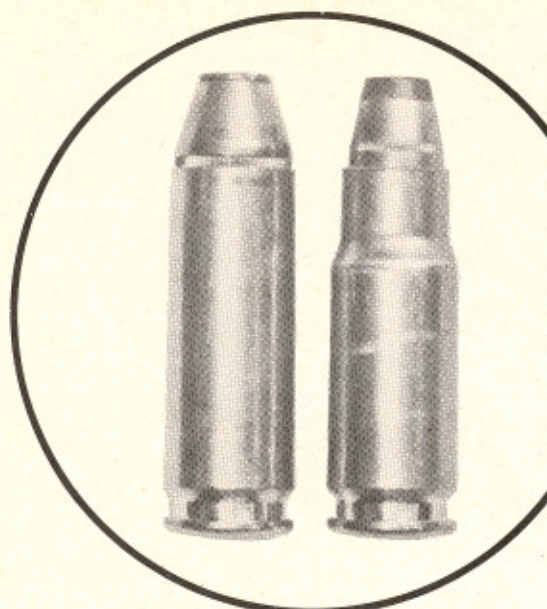

The .357 AMP case shown alongside a .44 AMP cartridge, at left for comparison, is simply the .44 AMP necked down. The case dimension drawing shows .357 AMP factory case specifications.

factory-loaded .357 AMP ammunition. Incidentally, as this is written, it appears that the price will be \$18.50 per box of 50 rounds, packed in a re-useable, hinged-lid compartmented plastic box.

[Ed. Note — In the last issue of *Handloader* in the article on the .44 AMP, it was mentioned that High Standard would be marketing Auto Mag pistols. However, we have since received a brochure from Lee Jurras and Associates, Inc., which states that they are exclusive worldwide distributors for the AMP. The brochure also states that "Much was written in the early part of '74, suggesting that the High Standard Co. would buy the manufacturing rights to and sell the AMP. Although High Standard did list the gun and some AMP's were made with their markings, the sale never did actually occur. Instead, in mid '74, the T.D.E. Corp. [manufacturers of the AMP] refinanced and tooled up to produce completely new guns to be distributed by the L.E. Jurras firm. New guns distributed by L.E. Jurras and Associates, Inc. will carry the conventional T.D.E. markings and will also be emblazoned with the lion's head logo of the Jurras firm. . . Sales and distribution rights to the Auto Mag Pistol were assigned formally to L.E. Jurras and Associates, Inc. in September '74. The new company, located in Shelbyville, Indiana, is headed by L.E. Jurras, founder and president of the Super Vel Cartridge Corporation." Suggested retail price is \$495 in either .357 AMP or .44 AMP, with either 6½ or 8½-inch barrel; this is the same price quoted by High Standard. — R. J.]

First, it has the capability of producing 2,200 fps at normal working pressures in the 8½-inch-barrel AMP pistol. It can achieve this velocity with jacketed .355-diameter bullets in the 120 to

135-grain weight range, and can drive the lighter 90 to 110-grain projectiles a good bit faster for those who fancy them. However, reliable functioning isn't possible with light bullets — they can't produce sufficient recoil energy at acceptable chamber pressures, even when the 90-grain bullet is driven to nearly 3,000 fps.

The heavier bullets retain velocity better, produce flatter long-range trajectories, and seem more versatile. In field tests we've found that at 200 yards, 125 and 137-grain bullets drop only about eight inches below the 100-yard point of impact. That is mighty flat shooting, beating all other handgun loads, and a few rifles as well. Loads in this same range have shown a clear capability of producing consistent four-inch groups at 100 yards in the hands of competent marksmen.

On big game ranging in size from pronghorn antelope to moose, bullet

performance has been surprisingly good. Tissue damage and wound cavities on the smaller species has been comparable to that produced by the .30-30 Winchester out to over 200 yards. In fact, at the longer ranges, the .357 AMP seems to do a little better than the .30-30 — doubtless because of its larger bullet diameter and much thinner bullet jacket.

On moose, the 137-grain bullet has punched completely through the neck near its base, and has also penetrated to and completely shattered the larger neck vertebrae. This occurred on 60-yard shots taken by Jurras on the Alaskan Peninsula last fall.

In between those species, the .357 AMP has cleanly killed everything it has been used on to date. On varmints and smaller game it has been deadly out as far as the target can be hit. Coyotes, jacks, crows, badgers, chucks, and others have been taken out to 150 yards or so, and no animal hit has yet been lost. The only



New Super Vel factory-loaded .357 AMP ammunition will be packaged as shown. The factory ammunition, which will sell for \$18.50 per 50 rounds, will eliminate the need for case forming to obtain brass.

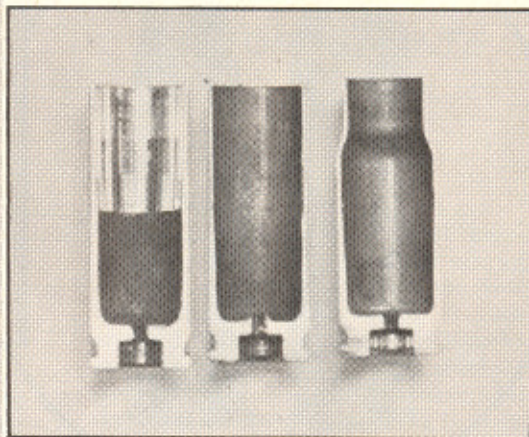

This sequence illustrates the steps necessary to form .357 AMP cases from 7.62mm NATO brass. The case is first run into a form/trim die, the excess is sawed off, then the case is trimmed, neck reamed, resized, and the case mouth is flared. The sectioned cases above, from left, are the trimmed and reamed 7.62mm NATO formed to .44 AMP, and CDM .44; both are suitable for forming to .357 AMP, right.

disadvantage one might attribute to the .357 in smaller animals is that tissue destruction is too great if you plan on eating them. A tender young chuck smacked in the wishbone by the fast-stepping .357 JSP or JHP will be too torn up for the skillet. If one really needed to shoot edible small game with the .357 AMP, doubtless a strongly constructed, full-jacket bullet could be used with satisfaction. The only trouble is that existing .357/.38/9mm FMJ bullets are *not* constructed heavily enough to consistently stand the 2,000 fps required to function the gun properly — they break up on impact and tear up nearly as much tissue as expanding bullets.

I think the best approach to this problem — if it really is important — is to swage your own FMJ bullets, using shortened .35 caliber *rifle* jackets reversed in the die. Their greater thickness should stand the impact without breaking up.

Handloading the .357 AMP isn't difficult, but it requires a bit more

attention than usual. In the absence of factory cases, we have two alternatives — reform C.D.M. .44 AMP brass, or form cases from the .308/.243/.30-06 class of brass (or, from .44 cases which have previously been formed from rifle cases; for information on forming .44 cases, as well as more detail on the Auto Mag, see the Sept.-Oct. 1974 *Handloader*.)

Reworking the C.D.M. .44 is by far the quickest and simplest. Though RCBS supplies a forming die set (forming die, and file-type trim die, with shell-holder extension) it isn't really necessary. Simply decap, clean, and lube (lightly) .44 AMP cases, then run them into the .357 AMP resizing die. Follow by trimming to a length of 1.298 inches, then chamfer the mouth. Finish by running case mouths over a .352 diameter expander plug. Unless your gun has an unusually tight

chamber, do not ream C.D.M. case necks as has sometimes been recommended — they won't need it; this isn't true for other brass. Flare case mouths just barely enough to permit starting a bullet.

Lacking C.D.M. .44 AMP cases, cut .308 brass to about 1.35-inch length and prepare for resizing. Run them into a .357 AMP form and trim die, and file the mouths flush with the top of the die. Chamfer the mouth inside and out, and wipe off all filings and chips.

Run the rough-formed and trimmed cases into the RCBS .357 AMP neck-reaming die, and carefully ream them. Be gentle with the reamer — clean it every three or four turns, and don't try to turn it by power.

Following this, the case can be run directly through the .357 AMP sizing die.

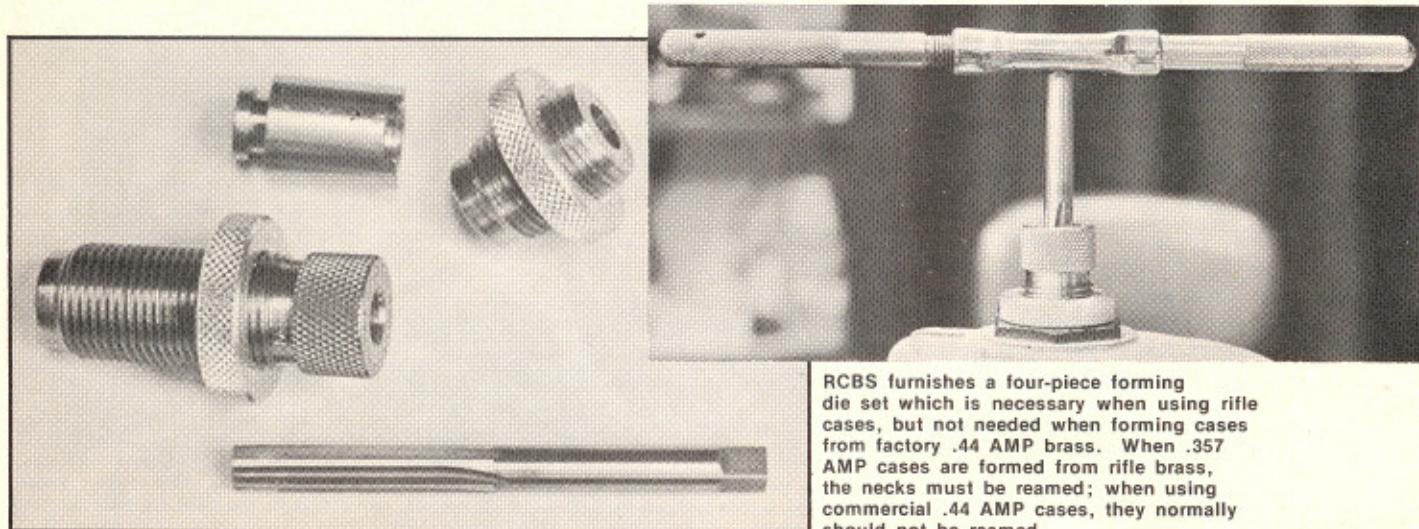

RCBS furnishes a four-piece forming die set which is necessary when using rifle cases, but not needed when forming cases from factory .44 AMP brass. When .357 AMP cases are formed from rifle brass, the necks must be reamed; when using commercial .44 AMP cases, they normally should not be reamed.

Then expand the necks to .352; make certain the necks aren't any larger than that — a tight fit on those .355-inch bullets is necessary. After washing or tumbling to clean, the cases can be loaded.

Better case life will be obtained, though, if necks are annealed first. In fact, I prefer to anneal them in molten lead before final resizing — right after reaming and before tumbling or cleaning. Any case that can be used to make the .357 AMP will be much harder at the new neck location than is desirable. Forming work-hardens them further. Without annealing, this can produce cracked or split necks in short order. It would be a shame to allow cases made at such great effort to be spoiled from lack of annealing.

On the other hand, .357 cases made from unfired .44 brass should be okay without annealing, at least for several loadings. If several-times-fired .44 cases are used, though, then they should be annealed after forming, and it may be necessary to anneal both before and after forming.

With cases in hand, you can get on with the loading. First, take a look at our load data and choose what suits you best. Don't look for lighter loads — there aren't any, simply because they wouldn't cycle the action correctly.

Pick your primer, powder, and bullet. Note there is not a wide variety of powders listed; others will work, after a fashion, but are not nearly as efficient as the ones we've listed. You'll have less grief if you stick to the ones we've tested. Do not pick what looks like the hottest load for a starter — it could be too hot in your particular gun. Instead, start a couple grains low, then work up, watching closely for signs of excess pressure.

Adjust your bullet-seating die to produce an overall cartridge length of 1.610 to 1.615-inch or less, seating the bullet *without* crimping. Then, after all bullets are so seated, re-adjust the die to remove the case mouth flare and just *barely* turn the mouth in upon the bullet — just the hint of a crimp. No greater crimp is needed, and applying a heavier crimp gratuitously may cause a slight bulge which will interfere with proper chambering.

Cycle the first completed round through the gun to insure that it chambers freely. Be sure to run this round *through the magazine* — if it is simply dropped in the chamber and the bolt is slammed shut on it, the extractor may be damaged. This could also wedge the cartridge tightly in the chamber if it did happen to be a hair oversize — then removing it would be an onerous chore.

For added insurance it has long been my practice to run *all* reformed-case loads

through the intended gun before a hunt. This is especially advisable here, for if you let just one case get through a few thousandths over-length, the crimping operation will probably bulge it enough to stick in the chamber. That could be embarrassing if you were facing an irritated grizzly.

Before considering the loading job done, fire at least ten rounds, noting whether all functions are as they should be. The gun must cycle fully with 100 percent reliability to qualify the load for hunting. Because of the light bullet, scarcely anything less than a full charge load will do so. It will require at least ten rounds (more is better) to insure that your particular load will cycle the gun *every* time. All the full-charge loads we show have functioned correctly in several different .357 AMP guns, but this can't guarantee there isn't a gun somewhere that might behave differently.

Like any other gun, the .357 AMP will stand some overloads, but their use will eventually produce excessive wear, parts

breakage, and other damage. To obtain the best results from your Auto Mag, do not exceed our top loads — and if you want to baby it a bit (not necessary), drop powder charges slightly to the lowest level that produces 100 percent functional reliability. Velocity will still be right up there, well above anything you can obtain in any other gun so don't feel you are cheating yourself.

The .357 AMP is a thoroughbred hunting handgun. As such, it requires a bit more care and attention, and a bit more attention to its ammunition, than say, a Colt .45 auto or a S&W M-10. Given the proper care and ammunition, it will do things no other handgun can even approach. If high levels of performance are your bag, then here is a gun/cartridge combination you'll like. ●

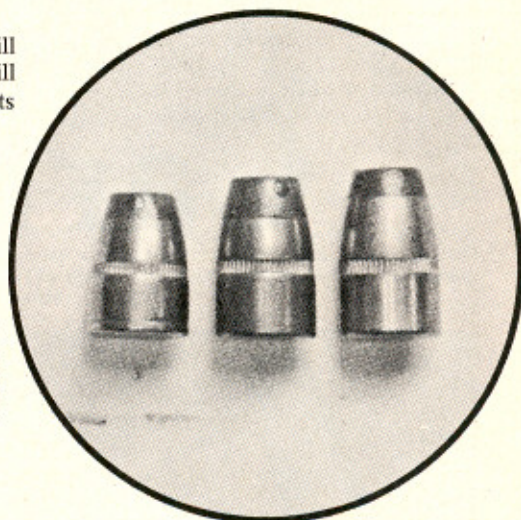

According to Nonte, maximum performance is obtained from the .357 AMP only within this bullet range. From left are the 110-grain JSP, 125-grain JHP, and 137-grain JSP.

### Load Data for the .357 AMP

Case	Primer	Bullet	Powder	Charge	Velocity	Pressure
1)	CCI 350	125 JHP	WW-630	20.0	1,740 fps	45,000 c.u.p.
2)	CCI 350	137 JSP	H-110	26.0	1,943 fps	49,000 c.u.p.
3)	CCI 350	137 JSP	H-110	27.0	1,930 fps	48,000 c.u.p.
4)	CCI 350	137 JSP	WW-630	19.0	1,630 fps	43,000 c.u.p.
5)	CCI 350	137 JSP	WW-630	18.5	1,606 fps	42,000 c.u.p.
6)	CCI 350	137 JSP	H-4227	24.0	1,680 fps	43,000 c.u.p.
7)	CCI 350	137 JSP	H-4227	23.0	1,630 fps	40,000 c.u.p.
8)	CCI 350	137 JSP	WW-296	22.0	1,675 fps	35,000 c.u.p.
9)	CCI 350	137 JSP	WW-296	26.0	1,902 fps	49,000 c.u.p.
10)	CCI 350	158 JSP	H-4227	23.0	1,643 fps	49,000 c.u.p.
11)	CCI 350	158 JSP	WW-630	17.0	1,486 fps	41,000 c.u.p.

These loads were developed with cases formed from .44 AMP brass; cases formed from rifle brass may have less capacity, requiring a reduction in charges to maintain equal pressures. Loads 5, 7, 8 and 11 will not produce reliable gun cycling and may be increased from .5 to one grain to do so. They are included to show the relatively high pressure and velocity levels which are essential with the AMP pistol; it doesn't like *light* loads. Loads two and three are the most versatile of the lot, and are the standard loads adopted by many owners of .357 AMP pistols. Zeroed at 100 yards, this load drops roughly 8 inches at 200 yards, with standard open sights.