

**SHOOTER'S MANUAL**

# **.44 AUTO MAG PISTOL**

**MODEL 180**



**AUTO MAG CORPORATION**

**PASADENA CALIFORNIA, U.S.A.**

**MAY 1971**

## .44 AUTO MAG PISTOL, MODEL 180

Maximum enjoyment of your favorite shooting sport is the reason why this .44 Auto Mag Shooter's Manual was written. Be sure to read it thoroughly, including the Warranty and Statement of Liability.

## NOTE

The last page folds out to provide an exploded view illustration of the pistol for reference while reading the Manual.

## MANUAL CONTENTS

<u>Subject</u>	<u>Page</u>	<u>Subject</u>	<u>Page</u>
WARRANTY . . . . .	2	SETTINGS AND ADJUSTMENTS . . . . .	8
STATEMENT OF LIABILITY . . . . .	2	Sight Adjustments . . . . .	8
GENERAL DESCRIPTION . . . . .	3	Changing Front Sight Blade Insert . . . . .	8
.44 Auto Mag Pistol . . . . .	3	Trigger Settings . . . . .	
Magazine . . . . .	3	LOADING, FIRING, AND UNLOADING . . . . .	10
Carrying Case . . . . .	4	Safety Practices . . . . .	10
Hex Head Wrenches . . . . .	4	Magazine Loading . . . . .	10
Auto Mag Gun Oil . . . . .	4	Pistol Loading . . . . .	11
Front Sight Blade Insert Material . . . . .	4	Suggestion for Easy Cocking . . . . .	11
SPECIAL NOTICES . . . . .	5	Firing . . . . .	11
FUNCTIONING OF THE PISTOL . . . . .	5	Carrying the Pistol When Loaded . . . . .	12
Feeding . . . . .	6	Unloading the Pistol . . . . .	12
Locking . . . . .	6	Unloading the Magazine . . . . .	12
Firing . . . . .	6	NORMAL MAINTENANCE . . . . .	12
Unlocking . . . . .	6	Disassembly (Field Stripping) . . . . .	12
Extracting . . . . .	7	Cleaning . . . . .	13
Ejecting . . . . .	7	Reassembly . . . . .	14
Cocking . . . . .	7	FACTORY SERVICE . . . . .	16
Safety Lever Operation . . . . .	8	SPARE AND REPAIR PARTS . . . . .	17
		Domestic Orders . . . . .	18
		Orders from Foreign Countries . . . . .	18

## WARRANTY

If the purchaser completely fills out the WARRANTY REGISTRATION CARD furnished with the gun and returns it to Auto Mag Corporation within ten days of the date of purchase, then Auto Mag Corporation for a period of one year from date of registered purchase will, at its option, repair or replace without charge the gun or any part thereof, provided it is returned prepaid to the factory and it is determined by Auto Mag Corporation in its sole discretion to be defective due to faulty material or improper workmanship. This constitutes the sole and exclusive remedy for breach of any warranty, expressed or implied, and supercedes any other warranties and commitments.

## STATEMENT OF LIABILITY

This gun is classified as a FIREARM or DANGEROUS WEAPON and is surrendered by Auto Mag Corporation with the express understanding that it assumes no liability to any person other than the owner whose warranty is registered with Auto Mag Corporation, no liability resulting from unsafe handling, no liability arising from conduct constituting a violation under any applicable laws or regulations, nor any other liability except as expressly provided in the above warranty. Auto Mag Corporation shall not be liable for personal injury or injury to property resulting from (a) intentional, reckless, negligent, or accidental discharge; (b) the function of any gun subjected to influences beyond its control which may result from careless handling, improper usage, corrosion or neglect; (c) unauthorized adjustments, repairs, or alterations made outside of its factory; (d) the incorporation of any part not of its manufacture; (e) defective, improper, or reloaded ammunition. Auto Mag Corporation shall not be liable for any consequential damages resulting from any of the above. This statement of liability supercedes any other statements of liability, whether expressed or implied.

May 3, 1971

Auto Mag Corporation  
Pasadena, California, U. S. A.

## GENERAL DESCRIPTION

The .44 Auto Mag pistol is a semiautomatic, short recoil operated, rotary bolt, magazine fed, handgun. It is chambered specifically for the .44 AMP (Auto Mag Pistol) rimless cartridge. Magazine capacity is seven cartridges. The pistol is shipped from the factory in a rugged plastic carrying case complete with the following special accessory items:

1. A plastic pouch containing 3/32 and 5/64 inch hex head wrenches.
2. Extra red and yellow front sight blade insert material.
3. A 1/2 Fl. Oz. oval plastic bottle of Auto Mag Gun Oil.

These items are stowed beneath a removable rectangular piece of foam insert liner in the lower left hand corner of the carrying case.

### .44 AUTO MAG PISTOL

The .44 Auto Mag pistol is fabricated entirely of stainless steel except for the grips which are molded from an extremely tough polyurethane material especially formulated for the application.

SPECIFICATIONS .44 Auto Mag Pistol, Model 180	
Barrel Length	6.5 inches
Caliber	.44 AMP
Bore Diameter	0.422 inches (nominal)
Rifling	8 grooves, left hand twist, 1 turn in 18 inches
Length Overall	11.5 inches
Sight Radius	10.5 inches
Weight With Empty Magazine	57 ounces

The pistol has Patridge type, target sights mounted on a fully ventilated, serrated sight rib which is an integral part of the barrel and extension assembly. Front sight ramp insert material may be changed easily from red to yellow or vice versa. The rear sight is fully adjustable for windage and elevation and is serrated to reduce glare. The notch in the rear sightblade is outlined in white to help give a sharp sight picture under all shooting conditions.

Trigger foreplay and overtravel may be adjusted to suit the shooter's individual preferences.

### MAGAZINE

The magazine for the .44 Auto Mag is fabricated entirely of stainless steel. Maximum magazine capacity is seven rounds.

### CARRYING CASE

The carrying case is made of high impact polypropylene plastic with a formed interior of polyurethane foam. The lower left hand corner of the case interior is removable to provide a pocket for carrying a 50-round plastic ammunition box of .44 AMP cartridges. The case has an integral handle which folds out of the way when not needed.

#### **CAUTION**

It is possible to inadvertently open the case latch if, (a) the fingers are allowed to trip the latch when picking the case up by the handle, (b) excessive force is applied to the handle when it is in the upward position or, (c) the handle is used as a lever to apply pressure against the case lid. Avoid doing any of the above.

### HEX HEAD WRENCHES

The 3/32 and 5/64 inch standard "L" type hex head wrenches contained in the plastic pouch are the only tools required to make all normal adjustments, or to tighten or remove any of the threaded parts used in the .44 Auto Mag.

### AUTO MAG GUN OIL

Auto Mag Gun Oil is a unique lubricant specially formulated to provide smooth pistol functioning over a wide temperature range. It was developed after Auto Mag had tested many commercially available gun oils and greases and found that the stainless steel .44 Auto Mag pistol requires a different type of lubricant than ordinary carbon steel guns.

#### **WARNING**

The use of other lubricants on stainless steel Auto Mag pistols is not recommended, and may result in malfunction or damage to metal parts.

### FRONT SIGHT BLADE INSERT MATERIAL

By a simple change of front sight blade insert color, the shooter can optimize his sight pattern for maximum visibility under different lighting conditions and background colorations.

A number of precautionary statements are contained throughout the text of this Shooter's Manual. For the reader's convenience, some of the most important are summarized below.

- Verify that the pistol is not loaded before handling or disassembly. If the pistol contains a magazine, release it by pressing the magazine latch on the left side of frame to the rear of the trigger guard and then remove it by withdrawing it from the butt of the pistol handle. Pull the cocking piece fully to the rear and inspect the chamber visually through the open ejection port to be sure that the pistol is not loaded.
- Do not use ammunition of any other type than that specifically designed for the pistol.
- Never load a live cartridge directly into the chamber of the pistol. The pistol is designed to feed from the magazine.
- Always fire the pistol at full arm's length from the body.
- Disassembly further than for normal maintenance should be performed only by an experienced gunsmith or as a part of factory servicing.
- The use of lubricants other than Auto Mag Gun Oil on stainless steel Auto Mag pistols is not recommended, and may result in malfunction or damage to metal parts.

Be sure to read your Shooter's Manual thoroughly, and heed its recommendations.

#### FUNCTIONING OF THE PISTOL

Each time a cartridge is fired, the parts within the pistol function in a given order or cycle of operation. The .44 Auto Mag's cycle of operation is divided into seven basic steps which are listed below in the order in which they occur. More than one step may be occurring at the same time. In the text which follows, numbers in parenthesis refer to parts shown on the exploded view illustration of the pistol which may be folded out from the past page for easy reference.

1. Feeding - Moving the cartridge from the magazine into the chamber.
2. Locking - Holding the cartridge in the chamber, and engaging the locking lugs on the bolt with those on the barrel extension.
3. Firing - Igniting the primer and firing the cartridge.
4. Unlocking - Disengaging the locking lugs on the bolt from those on the barrel extension.
5. Extracting - Removing the cartridge case from the chamber.
6. Ejecting - Discarding the cartridge case from the pistol.
7. Cocking - Returning the firing mechanism to the cocked position ready to fire another cartridge.

## FEEDING

Inserting a loaded magazine into the handle of the pistol (barrel and extension (1) forward, and bolt (22) locked in the breech), will bring the top cartridge in the magazine in contact with the bottom of the bolt. Further insertion pushes the ammunition deeper into the magazine, forcing the follower down, and further compressing the magazine spring. When the magazine is fully seated in the handle of the pistol, the magazine latch (57) engages the magazine (15) and locks it in place. Pulling the cocking piece (18) fully to the rear will allow the expanding magazine spring to force the follower and the ammunition up until the top cartridge is caught and held ready for chambering by the magazine lips. At this point, the recoil springs (17) are fully compressed, and the hammer (51) is cocked.

The cocking piece is then released. The expanding recoil springs force the bolt and cocking piece forward. The lower portion of the moving bolt face passes between the lips of the magazine, strips the top cartridge from the magazine, and pushes it forward to contact and travel up the feed ramp and into the chamber. The cartridge is chambered when the bolt has completed its forward motion relative to the barrel and extension assembly. At this time, the returning cocking piece contacts the rear of the barrel extension.

## LOCKING

The bolt and cocking piece in conjunction with the barrel and extension assembly now move forward as a group from the force of the still expanding recoil springs. During the last part of this motion, the helical portion of the internal caming surface of the bolt comes in contact with the bolt rotation pin (21). The bolt rotation spring (23) causes the bolt to rotate as directed by the helix until the six bolt locking lugs are securely engaged with those within the barrel and extension assembly. Finally, the forward motion of all moving parts is stopped by the barrel latch (60). The pistol is then ready for firing.

## FIRING

In order for the .44 Auto Mag to fire, the bolt must be fully forward and locked in the breech so that bolt safety tappet (44) will connect the trigger bar (36) to the sear (42).

When the trigger (38) is squeezed, the trigger bar engages the sear which rotates on the sear pin (41), and disengages from the full cock notch of the hammer. The expanding pair of nested hammer springs (55 and 56) push the hammer strut guide (54) upwards along with the hammer strut (53), forcing the hammer to rotate forward on the hammer pin (50) and to strike the firing pin (19).

The inertia type firing pin travels forward, compressing the firing pin spring (20). The firing pin moves through the firing pin well in the face of the bolt and strikes the cartridge primer. The primer ignites, firing the cartridge. The firing pin spring then expands and withdraws the firing pin from the face of the bolt.

## UNLOCKING

The pressure of the powder gases while driving the bullet forward, forces the barrel and extension assembly, bolt, and cocking piece rearward together. Their total weight which is much greater than that of the bullet when combined with the resistance of the recoil springs, makes them react more slowly than the bullet. This allows the bullet to leave the barrel before unlocking of the bolt begins. The unlocking is caused by the engagement of the helical portion of the internal caming surface of the bolt with the bolt rotation pin. The unlocked bolt and

cocking piece continue to travel a short distance further in unison with the barrel and extension assembly. The accelerator (4) then contacts a special locking lug on the bolt imparting a thrust to the bolt and cocking piece combination which separates them from the barrel and extension assembly and accelerates them towards the rear. Shortly thereafter, the rearward motion of the barrel and extension assembly is stopped when an internal shoulder contacts the ring on the top rear of the frame.

### EXTRACTING

As the bolt and cocking piece continue their rearward movement, the extractor (25) which is engaged in the extractor groove of the cartridge, withdraws the cartridge case from the chamber. Extraction is completed as the cartridge case clears the chamber.

### EJECTING

As the bolt continues to move rearward, the cartridge case, held in contact with the bolt by the extractor, reaches a point where the case mouth passes the front edge of the ejection port in the barrel extension. Since there is no longer any restraint placed on the lateral movement of the case, the spring loaded ejector (28) on the other side of the bolt face imparts a rotational motion to the case using the extractor as a pivot point, thus ejecting the cartridge case from the pistol.

### COCKING

Cocking begins as the cocking piece starts rearward in recoil. At first the cocking piece contacts the hammer, rotating it downwards to the rear, thus compressing the hammer spring pair through the force exerted by the hammer strut acting on the hammer strut guide. As the cocking piece continues its rearward travel, it passes over and beyond the hammer which remains restrained in a fully downward position by contact with the bottom surface of the bolt. When rearward motion of the bolt and cocking piece is stopped by the forward end of the slot in the bolt contacting the bolt rotation pin, the recoil springs then begin to expand, forcing the cocking piece and bolt forward again. The hammer remains depressed and restrained until the rear of the cocking piece moves far enough forward to allow the hammer to begin to rotate forward to follow it. This hammer motion only extends for a very short distance because the sear, which is bearing against the hammer through the action of the sear spring (43), engages the full cock notch of the hammer and holds it in the fully cocked position. By the time the bolt and cocking piece are fully forward and the shooter has released his trigger squeeze, the bolt safety tappet will be positioned in its recess in the bottom of the bolt, and the operating cycle is completed.

Subsequent steps in the cycle of operation of the pistol, feeding, locking, firing, etc., may be continued in order so long as there are cartridges in the magazine. When the magazine has been emptied, the holdopen (34) engages the bolt and holds it in the fully rearward position, thus serving as an indicator to remind the shooter that the empty magazine must be replaced with a loaded one.

Depressing the magazine latch releases the empty magazine from the handle of the pistol and permits insertion of a loaded magazine.

Pressing downward on the safety lever (45) releases the bolt from the open position allowing it to go forward to its locked position, carrying the top cartridge from the magazine into the barrel chamber, leaving the pistol cocked and ready for firing again.

## SAFETY LEVER OPERATION

The safety lever is located on the left side of pistol at the top rear of the grip. It may be actuated in two directions from the horizontal or "FIRE" position.

Rotating the safety lever fully upward as far as it will go will lock it into the "SAFE" position. When it is in the "SAFE" position the hammer is lifted off of the sear and locked back by the shaft of the safety lever; and the safety plate (32) is rotated to lock the sear in the full cock notch of the hammer as well as to engage the cocking piece thus locking it in the forward position.

When the safety lever is depressed from the horizontal or "FIRE" position to the "RELEASE" position, it acts as a bolt release by disengaging the holdopen, thus allowing the bolt to close. The "RELEASE" position is spring loaded, and the safety lever will automatically return to the "FIRE" position when released.

## SETTINGS AND ADJUSTMENTS

The rear sight on the .44 Auto Mag is fully adjustable for elevation and windage. In addition, the shooter may change the color of the front sight insert. Trigger foreplay and overtravel are also adjustable. In the text which follows, numbers in parenthesis refer to parts shown on the exploded view illustration of the pistol.

### SIGHT ADJUSTMENTS

Use the 5/64 inch hex head wrench to make rear sight adjustments. Each click of elevation or windage adjustment causes a one minute change in sight angle.

The elevation adjustment screw (8) is located in the center of the top surface of the rear sight platform (6). Clockwise rotation raises the rear sight blade (10); and counterclockwise rotation lowers it. The point of bullet impact will move in the same direction as the vertical motion of the sight blade.

The windage adjustment screw (9) is located on the right side of the rear sight platform. Clockwise rotation moves the rear sight blade to the left; and counterclockwise rotation moves it to the right. The point of bullet impact will move in the same direction as the horizontal motion of the sight blade.

### CHANGING FRONT SIGHT BLADE INSERT

Peel the undesired piece of colored insert material (64) from the front sight blade on the barrel and extension assembly (1) with a sharp knife blade. Clean the exposed metal surface with a few drops of solvent on a cleaning patch and wipe dry.

Use the knife to slit and remove a small rectangular piece of backing from one end of a strip of sight blade insert material of the chosen color. The exposed adhesive surface should be slightly wider than the sight blade.

**CAUTION**

Insert material will not adhere to the sight blade if the exposed adhesive surface is touched or contaminated.

Use the strip of insert material as a handle to locate the exposed adhesive surface immediately above the shallow notch in the sight blade ramp. Press the insert material into place and rub it several times to assure good adhesion. Cut off the extending strip, and then trim off the excess insert material projecting on either side of the sight blade.

### TRIGGER SETTINGS

Both trigger foreplay and trigger overtravel may be adjusted to suit the shooter's individual preferences. The 5/64 hex head wrench is used to make trigger adjustments.

**CAUTION**

Before making any adjustments, the shooter should fire the pistol enough times to become familiar with the factory trigger settings.

The trigger foreplay adjustment screw (33) is located in the top of the frame immediately above the trigger (38). The barrel and extension assembly must be removed from the frame (63) in order to gain access to it (see steps 1 and 2 of the Disassembly Sequence described in the section on Normal Maintenance). Clockwise rotation decreases trigger foreplay.

**CAUTION**

Insufficient trigger foreplay may make the pistol action inoperative after firing one cartridge.

Counterclockwise rotation increases trigger foreplay. Note: Excessive trigger foreplay is not conducive to accurate shooting.

The trigger overtravel adjustment screw (33) is located in the center of the trigger and may be adjusted without pistol disassembly. Clockwise rotation decreases trigger overtravel.

**CAUTION**

Insufficient trigger overtravel may make it impossible to fire the pistol.

Counterclockwise rotation increases trigger overtravel. Note: Excessive trigger overtravel is not conducive to accurate shooting.

When you purchased a .44 Auto Mag pistol, you became the owner of the most advanced and powerful production handgun now made. When used correctly by a competent person, it is probably the safest of all handguns. Before proceeding to use it, read this section on safe practices, loading, firing, and unloading very carefully. In the text which follows, numbers in parenthesis refer to parts shown on the exploded view illustration of the pistol.

### SAFETY PRACTICES

There are many safety rules set forth for handling firearms. Those which follow are basic, and should be rigidly observed.

1. Always check your .44 Auto Mag for live ammunition when it is picked up, drawn from a holster, or handed to or accepted from another individual.
2. Keep your pistol holstered or in its carrying case unless it is removed for a specific purpose.
3. Never point your .44 Auto Mag at anything that you do not intend to shoot.
4. Do not cock your pistol unless you intend to shoot it, and do not insert your finger into the trigger guard until you are ready to fire.
5. Dry-firing, even with dummy cartridges is to be discouraged unless performed on a regular target range, or at a known, inanimate target object.
6. Always be certain that the muzzle of your .44 Auto Mag is pointed in a safe direction, whether the pistol is loaded or not.
7. Use a very heavy backstop when target shooting with the .44 Auto Mag.
8. Make safe gun handling a habit.

### MAGAZINE LOADING

The .44 Auto Mag magazine has a capacity of seven cartridges. To load the magazine (15), hold it in one hand with the forward end of the follower in the same direction as the thumb and fingers of the holding hand. Place a cartridge on the forward end of the follower in front of the magazine lips, press down and to the rear with the cartridge head or base facing to rear of the magazine. The thumb of the hand holding the magazine may be used to exert a downward and rearward pressure on the cartridge while inserting it with the free hand. Succeeding cartridges are loaded in the same manner, one on top of another.

### **WARNING**

Do not use ammunition of any other type than that specifically designed for the pistol.

## PISTOL LOADING

If the pistol is to be fired immediately, make sure that the safety lever (45) is in the horizontal or "FIRE" position. Insert the loaded magazine into the pistol handle and push it in until it is engaged by the magazine latch (57) and locked in place.

If the bolt (22) is locked fully to the rear by engagement with the holdopen (34), press down on the safety lever to release it; if it is not, then pull the cocking piece (18) fully to the rear and release it. In either case, the top cartridge in the magazine will be chambered and the pistol will be cocked and ready for firing.

### **WARNING**

Never load a live cartridge directly into the chamber of the pistol. The pistol is designed to feed from the magazine.

## SUGGESTION FOR EASY COCKING

Pulling the cocking piece of your Auto Mag pistol fully to the rear is probably the most common manual actuation of the pistol action which you will make. It is required in order to verify that the pistol is safe, as well as to feed the first round from a loaded magazine into the chamber when the bolt and cocking piece are not held to the rear by the holdopen. To facilitate pulling the cocking piece to the rear, first rotate the hammer (51) manually to the rear until it is held in the full cock position. While holding the pistol handle securely with one hand, grasp the cocking piece with the thumb and forefinger of the other hand taking care to avoid possible contact with the rear sight blade (10). To bring the bolt and cocking piece fully to the rear, push the handle of the pistol away from the body while keeping the hand holding the cocking piece essentially stationary.

## FIRING

If the pistol is loaded and the shooter is not ready to fire, the safety lever should be rotated upward until it locks in the "SAFE" position. Before firing, the safety lever must be returned to the horizontal or "FIRE" position.

The rate of fire of the .44 Auto Mag is limited only by the shooter's ability to change magazines rapidly, aim, and squeeze the trigger.

The bolt and cocking piece come fully to the rear each time a cartridge is fired.

### **WARNING**

Always fire the pistol at full arm's length from the body.

## CARRYING THE PISTOL WHEN LOADED

When carrying the pistol in a holster, it should be carried with cartridges in the magazine only and the chamber empty. A cartridge should be chambered only at the time the pistol is to be fired.

The pistol should never be stored in a box or case with a live round in the chamber. When people other than the shooter have access to the pistol, the chamber should be empty; and if the magazine is loaded with cartridges, it should be removed from the pistol.

## UNLOADING THE PISTOL

Release the magazine by pressing the magazine latch on the left side of frame to the rear of the trigger guard and then remove it by withdrawing it from the butt of the pistol handle. Pull the cocking piece fully to the rear and inspect the chamber visually through the open ejection port to be sure that the pistol is not loaded.

## UNLOADING THE MAGAZINE

The cartridge in a magazine may be removed by pushing forward on the head of each cartridge until it is released from the magazine lips.

## NORMAL MAINTENANCE

Normal maintenance of the .44 Auto Mag pistol consists of disassembly (field stripping), cleaning, and reassembly. Even though the .44 Auto Mag is naturally resistant to rust and corrosion due to its stainless steel construction, it still requires proper cleaning to remove dirt, powder residue, brass shavings, and metal fouling in the bore which may accumulate after sustained firing. Thorough cleaning and proper lubrication of your .44 Auto Mag after every firing session will help maintain its inherent accuracy and assure its efficient operation.

In the text which follows, numbers in parenthesis refer to parts shown on the exploded view illustration of the pistol.

## DISASSEMBLY (FIELD STRIPPING)

### CAUTION

Verify that the pistol is not loaded before proceeding with its disassembly. If the pistol contains a magazine (15), release it by pressing the magazine latch (57) on the left side of the frame (63) to the rear of the trigger guard and then remove it by withdrawing it from the butt of the pistol handle. Pull the cocking piece (18) fully to the rear and inspect the chamber visually through the open ejection port to be sure that the pistol is not loaded.

## DISASSEMBLY SEQUENCE

Step No.	Procedure
1(a)	Insert an empty magazine into the pistol and pull the cocking piece fully to the rear until the holdopen (34) engages the bolt (22) and locks it and the cocking piece in the rear position; then remove the magazine.
1(b)	If an empty magazine is not used, pull the cocking piece fully to the rear and press the holdopen thumb piece located forward of the safety lever manually upward to engage the bolt and to lock it and the cocking piece in the rear position.
2	Rotate the barrel latch (60) down and forward until it stops. Then slide the barrel and extension assembly (1) forward and off of the pistol frame.
3	Pull the cocking piece to the rear to disengage the holdopen. While still holding the cocking piece, allow it and the bolt to travel forward slowly until the cocking piece motion is stopped by the ring on the top of frame leaving the hammer (51) cocked.
4	Using the 3/32 inch hex head wrench, remove the recoil rods (16) from the front end of the frame along with the recoil springs (17).
5	Pull the cocking piece fully to the rear, rotate it 1/4 turn counterclockwise, and disengage it from the bolt by a continued pull to the rear.
6	Remove the firing pin (19) and firing pin spring (20) from the bolt.
7	Push the safety lever (45) up to the "SAFE" position.
8	Push the bolt rotation pin (21) out to the left and remove it.
9	Slide the bolt in a rearward direction out of the ring in the frame.

The pistol is now disassembled sufficiently for proper cleaning and lubrication.

### WARNING

Further disassembly should be performed only by an experienced gunsmith or as a part of factory servicing.

### CLEANING

All cleaning should be performed using a good quality commercial nitro powder solvent. Care should be exercised to assure the thorough removal of all dirt, powder residue, brass shavings, metal fouling and other contaminants.

## CLEANING SEQUENCE

Step No.	Procedure
1	<p>Clean the bore and chamber from the rear as follows:</p> <p>(a) Run a dry cleaning patch through the bore and chamber several times.</p> <p>(b) Wet a cleaning patch with solvent and run it back and forth through the bore and chamber several times.</p> <p>(c) Continue to run wet cleaning patches through the bore and chamber until they are clean.</p> <p>(d) Inspect the bore and chamber for cleanliness. Repeat steps 1(a) through 1(c) as necessary until all residue is removed.</p>
2	Wipe the bolt clean with a cleaning patch soaked in solvent. Pay particular attention to the bolt face and the interior cam surfaces which contact the bolt rotation pin.
3	Clean all other exposed metal surfaces including those on the frame with cleaning patches soaked in solvent. Perform a careful visual inspection to assure that all metal surfaces are clean.

## REASSEMBLY

The reassembly of the pistol is done essentially in the reverse order of disassembly. Careful lubrication is an important part of the reassembly process. The use of Auto Mag Gun Oil is recommended.

### WARNING

The use of other lubricants on stainless steel Auto Mag firearms may result in malfunction or damage to metal parts.

## REASSEMBLY SEQUENCE

Step No.	Procedure
1	<p>Spread a light even film of Auto Mag Gun Oil on the following metal surfaces using a fresh cleaning patch:</p> <p>(a) Mating dovetail surfaces at the top front of the frame and on the block on the bottom of the barrel and extension assembly.</p> <p>(b) Accelerator (4)/accelerator block (3) mating surface.</p>

REASSEMBLY SEQUENCE (Continued)

Step No.	Procedure
1 cont.	(c) Cocking piece interior lugs which engage with the lugs on the rear of the bolt. (d) Surface of the bolt rotation pin. (e) Interior cam surfaces of the bolt. (f) Threads and surface of the recoil rods.
2	Make sure that the hammer is pulled back to the full cock notch and that the safety lever is rotated upward to the "SAFE" position.
3	From the rear, slide the bolt into the ring on the frame, and rotate the bolt so that the extractor (25) faces towards the right of the pistol frame.
4	Insert the bolt rotation pin through the frame ring and cam slot in the bolt body from the left making sure that it indexes and seats flush into the ring.
5	Pull the bolt fully to the rear, and depress the safety lever to horizontal or "FIRE" position.
6	Place the firing pin spring onto the firing pin and insert both parts into the bolt from the rear.
7	While holding the pistol frame, block the bolt's forward motion with a finger of the holding hand, then take the cocking piece in the other hand. Rotate it 1/4 turn counterclockwise from its normal position, engage it with the lugs on the rear of the bolt, rotate it 1/4 turn clockwise to its normal position, and then push it and the bolt fully forward slowly using the finger of the holding hand to help restrain forward bolt motion.
8	Slip the recoil springs onto the recoil rods and insert these assemblies into the frame tubes at the front of the frame. Mate each recoil rod with the cocking piece in turn. Insert a 3/32 inch hex head wrench into the head of a recoil rod, press to compress the recoil spring until engagement with the cocking piece is felt, and then screw in to tighten. <div data-bbox="630 1355 853 1444" style="text-align: center; border: 1px solid black; padding: 5px; margin: 10px auto; width: fit-content;"> <b>WARNING</b> </div> <p style="text-align: center;">Application of excessive force after full engagement is reached will damage self-locking inserts contained in the cocking piece.</p>

REASSEMBLY SEQUENCE (Continued)

Step No.	Procedure
9	<p>Lubricate remaining metal surfaces which come into contact with each other during function of the pistol with Auto Mag Gun Oil. These surfaces include the following:</p> <p>(a) Bolt body outside surface</p> <p>(b) Hammer pin (50)</p> <p>(c) Hammer strut pin (52)</p>
10(a)	Insert an empty magazine into the pistol and pull the cocking piece fully to the rear until the holdopen engages the bolt and locks it and the cocking piece in the rear position; then remove the magazine.
10(b)	If an empty magazine is not used, pull the cocking piece fully to the rear and press the holdopen thumb piece manually upward to engage the bolt and to lock it and the cocking piece in the rear position.
11	Make sure that the barrel latch is rotated down and forward as far as it will go.
12	Slide the barrel and extension assembly onto the pistol frame as far as it will go and rotate the barrel latch back to the locked position.
13	Pull the cocking piece to the rear to disengage the holdopen. While still holding the cocking piece, allow it and the bolt to travel forward slowly until cocking piece motion stops.
14	While restraining the hammer manually, pull the trigger, and allow the hammer to come to rest gently on the cocking piece.

FACTORY SERVICE

If your Auto Mag pistol should require repair, it is recommended that it be returned to the factory as there is no other way to assure that the work will be done in a properly staffed and equipped shop with parts of Auto Mag manufacture. Compliance with the following instructions will facilitate prompt service:

1. Remove custom grips, scopes, special sights, etc., before packing the gun for shipment. Do not include holsters or carrying cases. Auto Mag cannot assume responsibility for any of the above items.

2. Enclose a note with the pistol containing the following information:
  - (a) Your name and address.
  - (b) The type, model, and serial number of the gun being returned.
  - (c) Detailed information about the difficulty being experienced.
  - (d) Any specific instructions which you may have.
3. Pistols should be packed with proper care to protect them from damage during transit.
4. Address the package as follows:

To: Auto Mag Corporation  
660 South Arroyo Parkway  
Pasadena, California 91105  
U. S. A.
5. Mark the outside of the package in the lower left hand corner as follows:

ATTN: Service Department
6. Guns must be shipped to the factory prepaid. Auto Mag will not accept collect shipments.
7. By law, individuals are not permitted to send handguns through the mails. Shipment by Prepaid Railway Express is recommended.

When your pistol arrives at our Service Department it will be subjected to a careful inspection, and the note which you have enclosed with the gun will be reviewed in detail also. Then a quotation covering the total cost of the repair service to be performed will be sent to you. Charges will be based on the cost of parts replaced plus a labor charge for the actual time expended on the job subject to a minimum factory service charge of \$10.00. No actual work will be commenced before receiving your approval of our quotation unless you specifically authorize us to do so in writing beforehand.

#### SPARE AND REPAIR PARTS

.44 Auto Mag pistol parts listed in the accompanying table may be ordered directly from Auto Mag Corporation. Special shipping services, if requested, will increase order cost. Contact Auto Mag to determine the amount.

Compliance with the following instructions will facilitate prompt service:

1. Be sure that your order includes the following information:
  - (a) Your name and address.
  - (b) The type, model and serial number of the gun for which the parts are ordered.
  - (c) The quantity, part name and part/stock number of each item ordered.

2. Send your order to the following address:

Auto Mag Corporation  
P. O. Box 2468-D  
Pasadena, California 91105  
U. S. A.

3. Mark the outside of your mailing envelope in the lower left-hand corner as follows:

ATTN: Parts Department

#### DOMESTIC ORDERS

The following conditions are applicable to orders for spare and repair parts for delivery to addresses within the United States, including the District of Columbia, the Commonwealth of Puerto Rico, U. S. possessions and the Canal Zone:

1. Minimum Orders

(a) \$1.00 when prepaid by check or money order. No postage stamps, please. All normal shipping costs will be paid by Auto Mag.

(b) \$3.00 C.O.D. Purchaser pays all shipping costs and C.O.D. charges.

2. Sale to California Residents

Residents of the State of California must include 5% retail sales tax unless the parts ordered are for resale. Orders for parts for resale must so state, and must include the purchaser's retail seller's permit number.

#### ORDERS FROM FOREIGN COUNTRIES

The minimum order amount is \$5.00 for orders from foreign countries. Please write Auto Mag for a quotation before ordering. All prices will be quoted in U. S. Dollars, F. O. B. Auto Mag's factory in Pasadena, California, U. S. A. Shipping charges will be based on packed shipping weight, type of shipment, insurance and handling. Custom house broker's and consular fees, if any, are extra. If possible, all orders and inquiries should be in English.

Remittance must be in U. S. funds only and must accompany the order.

## SPARE AND REPAIR PARTS LIST

.44 AUTO MAG PISTOL, MODEL 180

NOTE: PRICES EFFECTIVE MAY 3, 1971 AND SUBJECT TO CHANGE WITHOUT NOTICE.

ITEM NO.	NOMENCLATURE OR DESCRIPTION	PART NUMBER	PRICE U. S. DOLLARS	REMARKS
1	BARREL & EXTENSION ASSY	100042-0001	120.00	
2	ACCELERATOR BLOCK PIN	100081-0005	1.00	See Note 1
3	ACCELERATOR BLOCK	100074-0001	10.90	
4	ACCELERATOR	100073-0001	11.10	
5	REAR SIGHT PIN	100070-0005	1.00	See Note 1
6	REAR SIGHT PLATFORM	100047-0001	11.30	
7	REAR SIGHT ELEVATION SPRING	100058-0001	.20	
8	ELEVATION ADJUSTMENT SCREW ASSY	100057-0001	3.50	
9	WINDAGE ADJUSTMENT SCREW ASSY	100057-0002	3.75	
10	REAR SIGHT BLADE	100045-0001	10.95	
11	REAR SIGHT WINDAGE SPRING	100059-0001	.20	
12	GRIP SCREW	100013-0001	.10	
13	LEFT GRIP	100064-0001	5.25	
14	RIGHT GRIP	100077-0001	5.25	
15	MAGAZINE ASSY	100056-0001	10.50	
16	RECOIL ROD	100072-0001	3.30	
17	RECOIL SPRING	100097-0001	1.60	
18	COCKING PIECE	100024-0001	13.25	
19	FIRING PIN	100031-0001	2.50	
20	FIRING PIN SPRING	100001-0001	.35	
21	BOLT ROTATION PIN	100060-0001	4.55	
22	BOLT	100041-0001	35.00	
23	BOLT ROTATION SPRING	100005-0001	.50	See Note 2
24	EXTRACTOR RETAINING PIN	100080-0001	.30	
25	EXTRACTOR	100082-0001	8.10	
26	EXTRACTOR SPRING	100098-0001	.65	
27	EJECTOR RETAINING PIN	100079-0001	.30	
28	EJECTOR	100071-0001	.55	
29	EJECTOR SPRING	100092-0001	.10	
30	RETAINING RING	100120-0002	.10	See Note 3
31	SAFETY PLATE SPACER	100121-0006	3.00	See Note 4
32	SAFETY PLATE	100065-0001	5.25	

## SPARE AND REPAIR PARTS LIST (Continued)

.44 AUTO MAG PISTOL, MODEL 180

NOTE: PRICES EFFECTIVE MAY 3, 1971 AND SUBJECT TO CHANGE WITHOUT NOTICE.

ITEM NO.	NOMENCLATURE OR DESCRIPTION	PART NUMBER	PRICE U.S. DOLLARS	REMARKS
33	TRIGGER ADJUSTMENT SCREW	100100-0001	.70	
34	HOLDOPEN ASSY	100083-0001	7.00	
35	HOLDOPEN SPRING	100075-0001	1.00	
36	TRIGGER BAR	100027-0001	5.25	
37	TRIGGER BAR SPRING	100003-0001	.45	
38	TRIGGER	100046-0001	6.65	
39	TRIGGER BAR PIN	100061-0005	1.00	See Note 1
40	TRIGGER SPRING	100004-0001	1.20	
41	SEAR PIN	100028-0005	1.00	See Note 1
42	SEAR	100017-0001	11.70	
43	SEAR SPRING	100032-0001	.25	
44	BOLT SAFETY TAPPET	100029-0001	3.00	
45	SAFETY LEVER	100025-0001	14.50	
46	SAFETY LEVER DETENT PLUNGER	100030-0001	3.00	
47	SAFETY LEVER DETENT SPRING (OUTER)	100099-0001	.80	See Note 5
48	SAFETY LEVER DETENT SPRING (INNER)	100109-0001	.80	See Note 5
49	HAMMER PIN RETAINING RING	100069-0001	.10	
50	HAMMER PIN	100068-0001	3.00	
51	HAMMER	100033-0001	10.20	
52	HAMMER STRUT PIN	100020-0005	1.00	See Note 1
53	HAMMER STRUT	100015-0001	3.60	
54	HAMMER STRUT GUIDE	100021-0001	.35	
55	HAMMER SPRING (OUTER)	100044-0001	.25	See Note 6
56	HAMMER SPRING (INNER)	100095-0001	.20	See Note 6
57	MAGAZINE LATCH	100022-0001	5.75	
58	MAGAZINE LATCH SPRING	100006-0001	.30	
59	MAGAZINE LATCH RETAINER	100023-0001	.60	
60	BARREL LATCH	100052-0001	2.40	
61	BARREL LATCH DETENT PLUNGER	100078-0001	.30	
62	BARREL LATCH DETENT SPRING	100002-0001	.65	
63	FRAME	100102-0001	-----	See Note 7
64	SIGHT INSERT MATERIAL	100117-0001	.15	RED
65	SIGHT INSERT MATERIAL	100117-0002	.15	YELLOW

## .44 AUTO MAG PISTOL, MODEL 180

## NOTES:

1. Part number is for a kit of four pins. Use the pin which gives .0003 to .0005 inch press fit. Do not use any pins which give a loose fit.
2. Bolt rotation spring is destroyed by removal from bolt.
3. Part number is for a kit consisting of two retaining rings. A retaining ring is destroyed by removal from the part on which it is assembled.
4. Part number is for a kit consisting of two each of five spacers of varying thickness. Use one or two spacers as required to provide .010 clearance between safety lever shoulder and frame.
5. Replacement of both inner and outer safety lever detent springs at the same time is recommended.
6. Replacement of both inner and outer hammer springs at the same time is recommended.
7. Not for sale.



.44

IL

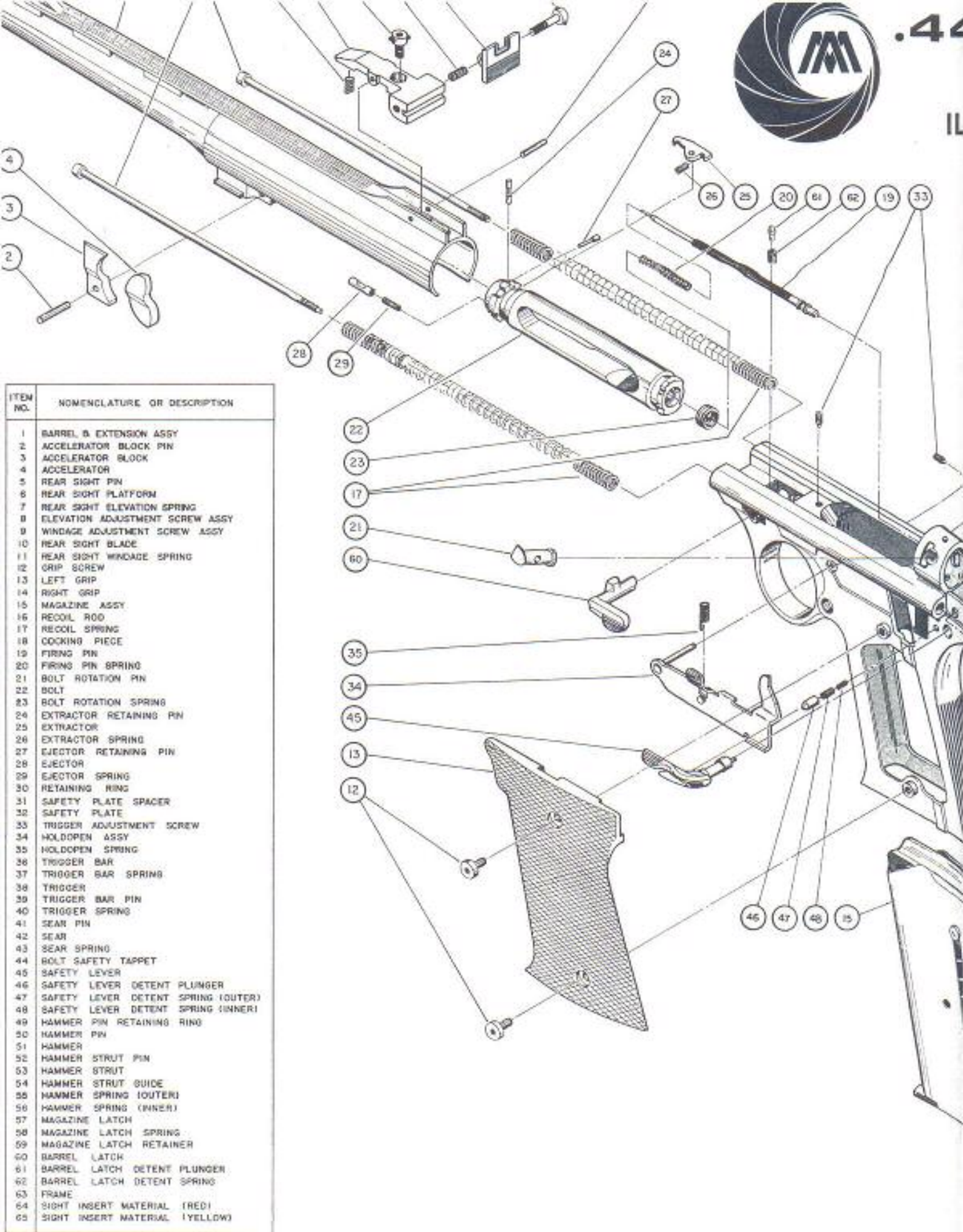

# .44 AUTO MAG

MODEL 180

## ILLUSTRATED PARTS LIST

