

# **.44 AUTO MAG PISTOL SHOOTER'S MANUAL**

**AUGUST, 1998**



**AUTOMAG, INC.**

**IRWINDALE, CALIFORNIA, U.S.A.**

# SHOOTER'S MANUAL

## AUTOMAG PISTOL

Maximum enjoyment of your favorite shooting sport is the reason why this AutoMag Shooter's Manual was written. Be sure to read it thoroughly, including the Warranty and Statement of Liability. Also be sure to study the sections marked **WARNING** and **CAUTION**.

### MANUAL CONTENTS

Subject	Page	Subject	Page
LIFETIME WARRANTY .....	1	LOADING, FIRING, AND UNLOADING .....	5
STATEMENT OF LIABILITY .....	2	Safety Practices .....	5
GENERAL DESCRIPTION .....	2	Magazine Loading .....	5
Fire Power Gun Oil .....	2	Pistol Loading .....	6
SPECIAL NOTICES .....	3	Suggestion for Easy Cocking .....	6
FUNCTIONING OF THE PISTOL .....	3	Firing .....	6
Feeding .....	4	Never Carry the Pistol When Loaded .....	6
Locking .....	4	Unloading the Pistol .....	6
Firing .....	4	Unloading the Magazine .....	6
Unlocking .....	4	NORMAL MAINTENANCE .....	6
Extracting .....	4	Disassembled (Field Stripping) .....	6
Ejecting .....	4	CLEANING .....	7
Cocking .....	4	REASSEMBLY .....	8
Safety Lever Operation .....	5	FACTORY SERVICE .....	9
SETTINGS AND ADJUSTMENTS .....	5	ILLUSTRATED PARTS LIST .....	10
Trigger Settings .....	5		

### LIFETIME WARRANTY

This warranty is voided by the use of hand loaded or reloaded ammunition, or if this firearm is modified in any manner from the original factory specifications.

## STATEMENT OF LIABILITY

This gun is classified as a FIREARM or DANGEROUS WEAPON and is surrendered by the Company with the express understanding that it assumes no liability to any person other than the owner whose warranty is registered with the Company, no liability resulting from unsafe handling, no liability arising from conduct constituting a violation under any applicable laws or regulations, nor any other liability except as expressly provided in the above warranty. The Company shall not be liable for personal injury or injury to property resulting from (a) intentional, reckless, negligent, or accidental discharge; (b) the function of any gun subjected to influences beyond its control which may result from careless handling,

improper usage, corrosion or neglect; (c) unauthorized adjustments, repairs, or alterations made outside of its factory; (d) the incorporation of any part not of its manufacture; or (e) defective, improper, or reloaded ammunition. The Company shall not be liable for any consequential damages resulting from any of the above. The Company will not be liable for any injury or damages to any person arising out of use of the Automag in hunting dangerous game, combat, civil defense or police activities as the AutoMag is not designed for any of these purposes. This statement of liability supercedes any other statements of liability, whether expressed or implied.

## GENERAL DESCRIPTION

The AutoMag pistol is a semiautomatic, short recoil operated, rotary bolt, magazine fed, handgun manufactured from stainless steel. It is chambered

specifically for the AMP (AutoMag Pistol) rimless cartridges. Magazine capacity is seven cartridges.

## FIRE POWER

Fire Power is a unique lubricant specially formulated to provide smooth pistol functioning over a wide temperature range. It was developed after AutoMag had tested many commercially available gun oils and

greases and found that the stainless steel AutoMag pistol requires a different type of lubricant than ordinary carbon steel guns.

### **WARNING**

*The use of other lubricants on stainless steel AutoMag pistols is not recommended, and may result in malfunction or damage to metal parts.*

## SPECIAL NOTICES

A number of precautionary statements are contained throughout the text of this Shooter's Manual. For the reader's convenience, some of the most important are summarized below.

- Verify that the pistol is not loaded before handling or disassembly. If the pistol contains a magazine, release it by pressing the magazine latch on the left side of frame to the rear of the trigger guard and then remove it by withdrawing it from the butt of the pistol handle. Pull the cocking piece fully to the rear and inspect the chamber visually through the open ejection port to be sure that the pistol is not loaded.

- Do not use ammunition of any other type than that specifically designed for the pistol.

- **Never load a live cartridge directly into the chamber of the pistol. The pistol is designed to feed from the magazine.**

- Always fire the pistol at full arm's length from the body.

- Disassembly further than for normal maintenance should be performed only by an experienced gunsmith or as a part of factory servicing.

- The use of lubricants other than AutoMag Gun Oil on stainless steel AutoMag pistols is not recommended, and may result in malfunction or damage to metal parts.

**Be sure to read your Shooter's Manual thoroughly and heed its recommendations.**

## FUNCTIONING OF THE PISTOL

Each time a cartridge is fired, the parts within the pistol function in a given order or cycle of operation. The AutoMag's cycle of operation is divided into seven basic steps which are listed below in the order in which they occur. More than one step may be occurring at the same time. In the text which follows, numbers in parenthesis refer to parts shown on the exploded view illustration of the pistol which may be folded out from the last page for easy reference.

1. Feeding— Moving the cartridge from the magazine into the chamber.
2. Locking— Holding the cartridge in the chamber, and engaging the locking lugs on the bolt with those on the barrel extension.
3. Firing— Igniting the primer and firing the cartridge.
4. Unlocking— Disengaging the locking lugs on the bolt from those on the barrel extension.
5. Extracting— Removing the cartridge case from the chamber.
6. Ejecting— Discarding the cartridge case from the pistol.
7. Cocking— Returning the firing mechanism to the cocked position ready to fire another cartridge.

#### FEEDING

Inserting a loaded magazine into the handle of the pistol (barrel and extension (1) forward, and bolt (22) locked in the breech), will bring the top cartridge in the magazine in contact with the bottom of the bolt. Further insertion pushes the ammunition deeper into the magazine, forcing the follower down, and further compressing the magazine spring. When the magazine is fully seated in the handle of the pistol, the magazine latch (57) engages the magazine (15) and locks it in place. Pulling the cocking piece (18) fully to the rear will allow the expanding magazine spring to force the follower and the ammunition up until the top cartridge is caught and held ready for chambering by the magazine lips. At this point, the recoil springs (17) are fully compressed, and the hammer (51) is cocked. The cocking piece is then released. The expanding recoil springs force the bolt and cocking piece forward. The lower portion of the moving bolt face passes between the lips of the magazine, strips the top cartridge from the magazine, and pushes it forward to contact and travel up the feed ramp and into the chamber. The cartridge is chambered when the bolt has completed its forward motion relative to the barrel and extension assembly. At this time, the returning cocking piece contacts the rear of the barrel extension.

#### LOCKING

The bolt and cocking piece in conjunction with the barrel and extension assembly now move forward as a group from the force of the still expanding recoil springs. During the last part of this motion, the helical portion of the internal camming surface of the bolt comes in contact with the bolt rotation pin (21). The bolt rotation spring (23) causes the bolt to rotate as directed by the helix until the six bolt locking lugs are securely engaged with those within the barrel and extension assembly. Finally, the forward motion of all moving parts is stopped by the barrel latch (60). The pistol is then ready for firing.

#### FIRING

In order for the AutoMag to fire, the bolt must be fully forward and locked in the breech so that bolt safety tappet (44) will connect the trigger bar (36) to the sear (42). When the trigger (38) is squeezed, the trigger bar engages the sear which rotates on the sear pin (41), and disengages from the full cock notch of the hammer. The expanding pair of nested hammer springs (55 and 56) push the hammer strut guide (54) upwards along with the hammer strut (53), forcing the hammer to rotate forward on the hammer pin (50) and to strike the firing pin (19).

The inertia type firing pin travels forward, compressing the firing pin spring (20). The firing pin moves through the firing pin well in the face of the bolt and strikes the cartridge primer. The primer ignites, firing the cartridge. The firing pin spring then expands and withdraws the firing pin from the face of the bolt.

#### UNLOCKING

The pressure of the powder gases while driving the bullet forward, forces the barrel and extension assembly, bolt, and cocking piece rearward together. Their total weight which is much greater than that of the bullet when combined with the resistance of the recoil springs, makes them react more slowly than the bullet. This allows the bullet to leave the barrel before unlocking of the bolt begins. The unlocking is caused by the engagement of the helical portion of the

internal camming surface of the bolt with the bolt rotation pin. The unlocked bolt and cocking piece continue to travel a short distance further in unison with the barrel and extension assembly. The accelerator (4) then contacts a special locking lug on the bolt imparting a thrust to the bolt and cocking piece combination which separates them from the barrel and extension assembly and accelerates them towards the rear. Shortly thereafter, the rearward motion of the barrel and extension assembly is stopped when an internal shoulder contacts the ring on the top rear of the frame.

#### EXTRACTING

As the bolt and cocking piece continue their rearward movement, the extractor (25) which is engaged in the extractor groove of the cartridge, withdraws the cartridge case from the chamber. Extraction is completed as the cartridge case clears the chamber.

#### EJECTING

As the bolt continues to move rearward, the cartridge case, held in contact with the bolt by the extractor, reaches a point where the case mouth passes the front edge of the ejection port in the barrel extension. Since there is no longer any restraint placed on the lateral movement of the case, the spring loaded ejector (28) on the other side of the bolt face imparts a rotational motion to the case using the extractor as a pivot point, thus ejecting the cartridge case from the pistol.

#### COCKING

Cocking begins as the cocking piece starts rearward in recoil. At first the cocking piece contacts the hammer, rotating it downwards to the rear, thus compressing the hammer spring pair through the force exerted by the hammer strut acting on the hammer strut guide. As the cocking piece continues its rearward travel, it passes over and beyond the hammer which remains restrained in a fully downward position by contact with the bottom surface of the bolt. When rearward motion of the bolt cocking piece is stopped by the forward end of the slot in the bolt contacting the bolt rotation pin, the recoil springs then begin to expand, forcing the cocking piece and bolt forward again. The hammer remains depressed and restrained until the rear of the cocking piece moves far enough forward to allow the hammer to begin to rotate forward to follow it. This hammer motion only extends for a very short distance because the sear, which is bearing against the hammer through the action of the sear spring (43), engages the full cock notch of the hammer and holds it in the fully cocked position. By the time the bolt and cocking piece are fully forward and the shooter has released his trigger squeeze, the bolt safety tappet will be positioned in its recess in the bottom of the bolt, and the operating cycle is completed.

Subsequent steps in the cycle of operation of the pistol, feeding, locking, firing, etc., may be continued in order so long as there are cartridges in the magazine. When the magazine has been emptied, the holdopen (34) engages the bolt and holds it in the fully rearward position, thus serving as an indicator to remind the shooter that the empty magazine must be replaced with a loaded one.

Depressing the magazine latch releases the empty magazine from the handle of the pistol and permits insertion of a loaded magazine.

Pressing downward on the safety lever (45) releases the bolt from the open position allowing it to go forward to its locked position, carrying the top cartridge from the magazine into the barrel chamber, leaving the pistol cocked and ready for firing again.

#### SAFETY LEVER OPERATION

The safety lever is located on the left side of the pistol at the top rear of the grip. It may be actuated in two directions from the horizontal or "FIRE" position. Rotating the safety lever fully upward as far it will go will lock it into the "SAFE" position. When it is in the "SAFE" position the hammer is lifted off of the sear and locked back by the shaft of the safety lever and the safety plate (32) is rotated to lock the sear in the full cock notch of the hammer as well as to engage the cocking piece thus locking it in the forward position. When the safety lever is depressed from the horizontal or "FIRE" position to the "RELEASE" position, it acts as a bolt release by disengaging the holdopen, thus allowing the bolt to close. The "RELEASE" position is spring loaded, and the safety lever will automatically return to the "FIRE" position when released.

### SETTINGS AND ADJUSTMENTS

The rear sight on the AutoMag is fully adjustable for elevation and windage. Trigger foreplay and overtravel are also adjustable. In the text which follows, numbers in parenthesis refer to parts shown on the exploded view illustration of the pistol.

#### TRIGGER SETTINGS

Both trigger foreplay and trigger overtravel may be adjusted to suit the shooter's individual preferences. A 5/64 hex head wrench is used to make trigger adjustments.

### CAUTION

*Before making any adjustments the shooter should fire the pistol enough times to become familiar with the factory trigger settings.*

The trigger foreplay adjustment screw (33) is located in the top of the frame immediately above the trigger (38). The barrel and extension assembly must be removed from the frame (63) in order to gain access to it (see steps 1 and 2 of the Disassembly Sequence described in the section on Normal Maintenance). Clockwise rotation decreases trigger foreplay.

### CAUTION

*Insufficient trigger foreplay may make the pistol action inoperative after firing one cartridge.*

Counterclockwise rotation increases trigger foreplay. Note: Excessive trigger foreplay is not conducive to accurate shooting. The trigger overtravel adjustment screw (33) is located in the center of the trigger and may be adjusted without pistol disassembly. Clockwise rotation decreases trigger overtravel.

### CAUTION

*Insufficient trigger overtravel may make it impossible to fire the pistol.*

Counterclockwise rotation increases trigger overtravel. Note: Excessive trigger overtravel is not conducive to accurate shooting.

### LOADING, FIRING, AND UNLOADING

When you purchased an AutoMag pistol, you became the owner of the most advanced and powerful production handgun now made. When used correctly by a competent person, it is probably the safest of all handguns but still must be considered a dangerous weapon. Before proceeding to use your AutoMag, read this section on safe practices, loading, firing, and unloading very carefully. In the text which follows, numbers in parenthesis refer to parts shown on the exploded view illustration of the pistol.

#### SAFETY PRACTICES

There are many safety rules set forth for handling firearms. Those which follow are basic and should be rigidly observed.

1. Always check your AutoMag for live ammunition when it is picked up, drawn from a holster, or handed to or accepted from another individual.
2. Keep your pistol holstered or in its carrying case unless it is removed for a specific purpose.
3. Never point your AutoMag at anything that you do not intend to shoot.
4. Do not cock your pistol unless you intend to shoot it, and do not insert your finger into the trigger guard until you are ready to fire.
5. Dry-firing, even with dummy cartridges is to be discouraged unless performed on a regular target range, or at a known, inanimate target object.
6. Always be certain that the muzzle of your AutoMag is pointed in a safe direction, whether the pistol is loaded or not.
7. Use a very heavy backstop when target shooting with the AutoMag.
8. Make safe gun handling a habit.

#### MAGAZINE LOADING

The AutoMag magazine has a capacity of seven cartridges. To load the magazine (15), hold it in one hand with the forward end of the follower in the same direction as the thumb and fingers of the holding hand. Place a cartridge on the forward end of the follower in front of the magazine lips, press down and to the rear with the cartridge head or base facing to rear of the magazine. The thumb of the hand holding the magazine may be used to exert a downward and rearward pressure on the cartridge while inserting it with the free hand. Succeeding cartridges are loaded in the same manner, one on top of another.

## WARNING

*Do not use ammunition of any other type than that specifically designed for the pistol.*

### PISTOL LOADING

If the pistol is to be fired immediately, make sure that the safety lever (45) is in the horizontal or "FIRE" position. Insert the loaded magazine into the pistol handle and push it in until it is engaged by the magazine latch (57) and locked in place.

If the bolt (22) is locked fully to the rear by engagement with the holdopen (34), press down on the safety lever to release it; if it is not, then pull the cocking piece (18) fully to the rear and release it. In either case, the top cartridge in the magazine will be chambered and the pistol will be cocked and ready for firing.

## WARNING

*Never load a live cartridge directly into the chamber of the pistol. The pistol is designed to feed from the magazine.*

### SUGGESTION FOR EASY COCKING

Pulling the cocking piece of your AutoMag pistol fully to the rear is probably the most common manual actuation of the pistol action which you will make. It is required in order to verify that the pistol is safe, as well as to feed the first round from a loaded magazine into the chamber when the bolt and cocking piece are not held to the rear by the holdopen. To facilitate pulling the cocking piece to the rear, first rotate the hammer (51) manually to the rear until it is held in the full cock position. While holding the pistol handle securely with one hand, grasp the cocking piece with the thumb and forefinger of the other hand taking care to avoid possible contact with the rear sight blade (10). To bring the bolt and cocking piece fully to the rear, push the handle of the pistol away from the body while keeping the hand holding the cocking piece essentially stationary.

### FIRING

If the pistol is loaded and the shooter is not ready to fire, the safety lever should be rotated upward until it locks in the "SAFE" position. Before firing, the safety lever must be returned to the horizontal or "FIRE" position.

The rate of fire of the AutoMag is limited only by the shooter's ability to change magazines rapidly, aim, and squeeze the trigger. The bolt and cocking piece come fully to the rear each time a cartridge is fired.

## WARNING

*Always fire the pistol at full arm's length from the body. Never fire the pistol at eye level near the face because of the rearward propulsion of the bolt: this safety practice should be followed with all handguns.*

### NEVER CARRY THE PISTOL WHEN LOADED

When carrying the pistol in a holster, it should be carried with cartridges in the magazine only and the chamber empty. A cartridge should be chambered only at the time the pistol is to be fired.

The pistol should never be stored in a box or case with a live round in the chamber. When people other than the shooter have access to the pistol, the chamber should be empty; and if the magazine is loaded with cartridges, it should be removed from the pistol.

### UNLOADING THE PISTOL

Release the magazine by pressing the magazine latch on the left side of frame to the rear of the trigger guard and then remove it by withdrawing it from the butt of the pistol handle. Pull the cocking piece fully to the rear and inspect the chamber visually through the open ejection port to be sure that the pistol is not loaded.

### UNLOADING THE MAGAZINE

The cartridge in a magazine may be removed by pushing forward on the head of each cartridge until it is released from the magazine lips.

## NORMAL MAINTENANCE

Normal maintenance of the AutoMag pistol consists of disassembly (field stripping), cleaning, and reassembly. Even though the AutoMag is naturally resistant to rust and corrosion due to its stainless steel construction, it still requires proper cleaning to remove dirt, powder residue, brass shavings, and metal fouling in the bore which may accumulate after sustained firing. Thorough cleaning and proper lubrication of your pistol after every firing session will help maintain its inherent accuracy and assure its efficient operation.

In the text which follows, numbers in parenthesis refer to parts shown on the exploded view illustration of the pistol.

### DISASSEMBLY (FIELD STRIPPING)

## CAUTION

*Verify that the pistol is not loaded before proceeding with its disassembly. If the pistol contains a magazine (15), release it by pressing the magazine latch (57) on the left side of the frame (63) to the rear of the trigger guard and then remove it by withdrawing it from the butt of the pistol handle. Pull the cocking piece (18) fully to the rear and inspect the chamber visually through the open ejection port to be sure that the pistol is not loaded.*

# DISASSEMBLY SEQUENCE

- 1 (a) Insert an empty magazine into the pistol and pull the cocking piece fully to the rear until the holdopen (34) engages the bolt (22) and locks it and the cocking piece in the rear position; then remove the magazine.
- 1 (b) If an empty magazine is not used, pull the cocking piece fully to the rear and press the holdopen thumb piece located forward of the safety lever manually upward to engage the bolt and to lock it and the cocking piece in the rear position.
2. Rotate the barrel latch (60) down and forward until it stops. Then slide the barrel and extension assembly (1) forward and off of the pistol frame.
3. Pull the cocking piece to the rear to disengage the holdopen. While still holding the cocking piece, allow it and the bolt to travel forward slowly until the cocking piece motion is stopped by the ring on the top of the frame leaving the hammer (51) cocked.
4. Using a 3/32 inch hex head wrench, remove the recoil rods (16) from the front end of the frame along with the recoil springs (17).
5. Pull the cocking piece fully to the rear, rotate it 1/4 turn counterclockwise, and disengage it from the bolt by a continued pull to the rear.
6. Remove the firing pin (19) and firing pin spring (20) from the bolt.
7. Push the safety lever (45) up to the "SAFE" position.
8. Push the bolt rotation pin (21) out to the left and remove it.
9. Slide the bolt in a rearward direction out of the ring in the frame.

The pistol is now disassembled sufficiently for proper cleaning and lubrication.

## WARNING

*Further disassembly should be performed only by an experienced gunsmith or as a part of factory servicing.*

### CLEANING

All cleaning should be performed using a good quality commercial nitro powder solvent. Care should be exercised to assure the thorough removal of all dirt, powder residue, brass shavings, metal fouling and other contaminants.

# CLEANING SEQUENCE

1. Clean the bore and chamber from the rear as follows:
  - (a) Wet a cleaning patch with solvent and run it back and forth through the bore and chamber several times.
  - (b) Continue to run wet cleaning patches through the bore and chamber until they are clean.
  - (c) Run a dry cleaning patch through the bore and chamber several times.
  - (d) Inspect the bore and chamber for cleanliness. Repeat steps 1(a) through 1(c) as necessary until all residue is removed.
2. Wipe the bolt clean with a cleaning patch soaked in solvent. Pay particular attention to the bolt face and the interior cam surfaces which contact the bolt rotation pin.
3. Clean all other exposed metal surfaces including those on the frame with cleaning patches soaked in solvent. Perform a careful visual inspection to assure that all metal surfaces are clean.

### REASSEMBLY

The reassembly of the pistol is done essentially in the reverse order of disassembly. Careful lubrication is an important part of the reassembly process. The use of Firepower Oil is recommended.

## WARNING

*The use of other lubricants on stainless steel AutoMag firearms may result in malfunction or damage to metal parts.*

## REASSEMBLY SEQUENCE

1. Spread a light even film of Firepower Oil on the following metal surfaces using a fresh cleaning patch:
  - (a) Mating dovetail surfaces at the top front of the frame and on the block on the bottom of the barrel and extension assembly.
  - (b) Accelerator (4)/accelerator block (3) mating surface.
  - (c) Cocking piece interior lugs which engage with the lugs on the rear of the bolt.
  - (d) Surface of the bolt rotation pin.
  - (e) Interior cam surfaces of the bolt.
  - (f) Threads and surface of the recoil rods.
2. Make sure that the hammer is pulled back to the full cock notch and that the safety lever is rotated upward to the "SAFE" position.
3. From the rear, slide the bolt into the ring on the frame, and rotate the bolt so that the extractor (25) faces towards the right of the pistol frame.
4. Insert the bolt rotation pin through the frame ring and cam slot in the bolt body from the left making sure that it indexes and seats flush into the ring.
5. Pull the bolt fully to the rear, and depress the safety lever to horizontal or "FIRE" position.
6. Place the firing pin spring onto the firing pin and insert both parts into the bolt from the rear.
7. While holding the pistol frame, block the bolt's forward motion with a finger of the holding hand, then take the cocking piece in the other hand. Rotate it 1/4 turn counterclockwise from its normal position, engage it with the lugs on the rear of the bolt fully forward slowly using the finger of the holding hand to help restrain forward bolt motion.
8. Slip the recoil springs onto the recoil rods and insert these assemblies into the frame tubes at the front of the frame. Mate each recoil rod with the cocking piece in turn. Insert a 3/32 inch hex head wrench into the head of a recoil rod, press to compress the recoil spring until engagement with the cocking piece is felt, and then screw in to tighten.

### WARNING

*Application of excessive force after full engagement is reached will damage self-locking inserts contained in the cocking piece.*

9. Lubricate remaining metal surfaces which come into contact with each other during function of the pistol with Firepower Oil. These surfaces include the following:
  - (a) Bolt body outside surface
  - (b) Hammer pin (50)
  - (c) Hammer strut pin (52)
- 10(a) Insert an empty magazine into the pistol and pull the cocking piece fully to the rear until the holdopen engages the bolt and locks it and the cocking piece in the rear position; then remove the magazine.
- 10(b) If an empty magazine is not used, pull the cocking piece fully to the rear and press the holdopen thumb piece manually upward to engage the bolt and to lock it and the cocking piece in the rear position.
11. Make sure that the barrel latch is rotated down and forward as far as it will go.
12. Slide the barrel and extension assembly onto the pistol frame as far as it will go and rotate the barrel latch back to the locked position.
13. Pull the cocking piece to the rear to disengage the holdopen. While still holding the cocking piece, allow it and the bolt to travel forward slowly until cocking piece motion stops.
14. While restraining the hammer manually, pull the trigger, and allow the hammer to come to rest gently on the cocking piece.

## FACTORY SERVICE

If your AutoMag pistol should require repair, it is recommended that it be returned to the factory or a factory designated repair center as there is no other way to assure that the work will be done in a properly staffed and equipped shop with parts manufactured by the Company. Compliance with the following instructions will facilitate prompt service:

1. Remove custom grips, scopes, special sights, etc., before packing the gun for shipment. Do not include holsters or carrying cases. The Company will not assume responsibility for any of the above items.
2. Enclose a note with the pistol containing the following information:
  - (a) Your name and address.
  - (b) The caliber and serial number of the gun being returned.
  - (c) Detailed information about the difficulty being experienced.
  - (d) Any specific instructions which you may have.
3. Pistols should be packed with proper care to protect them from damage during transit.
4. Call the Company and determine the address of the repair center where the gun should shipped. The Company's telephone number is (626) 856-8883.
5. Mark the outside of the package in the lower left hand corner as follows:

ATTN: Service Department
6. Guns must be shipped prepaid. Collect shipments will be returned at shippers cost.
7. It is unlawful for individuals to send handguns through the mails. Shipment by Prepaid Railway Express is recommended.

When your pistol arrives at a repair center it will be subjected to a careful inspection, and the note which you have enclosed with the gun will be reviewed in detail also.

# AUTOMAG PISTOL

## ILLUSTRATED PARTS LIST

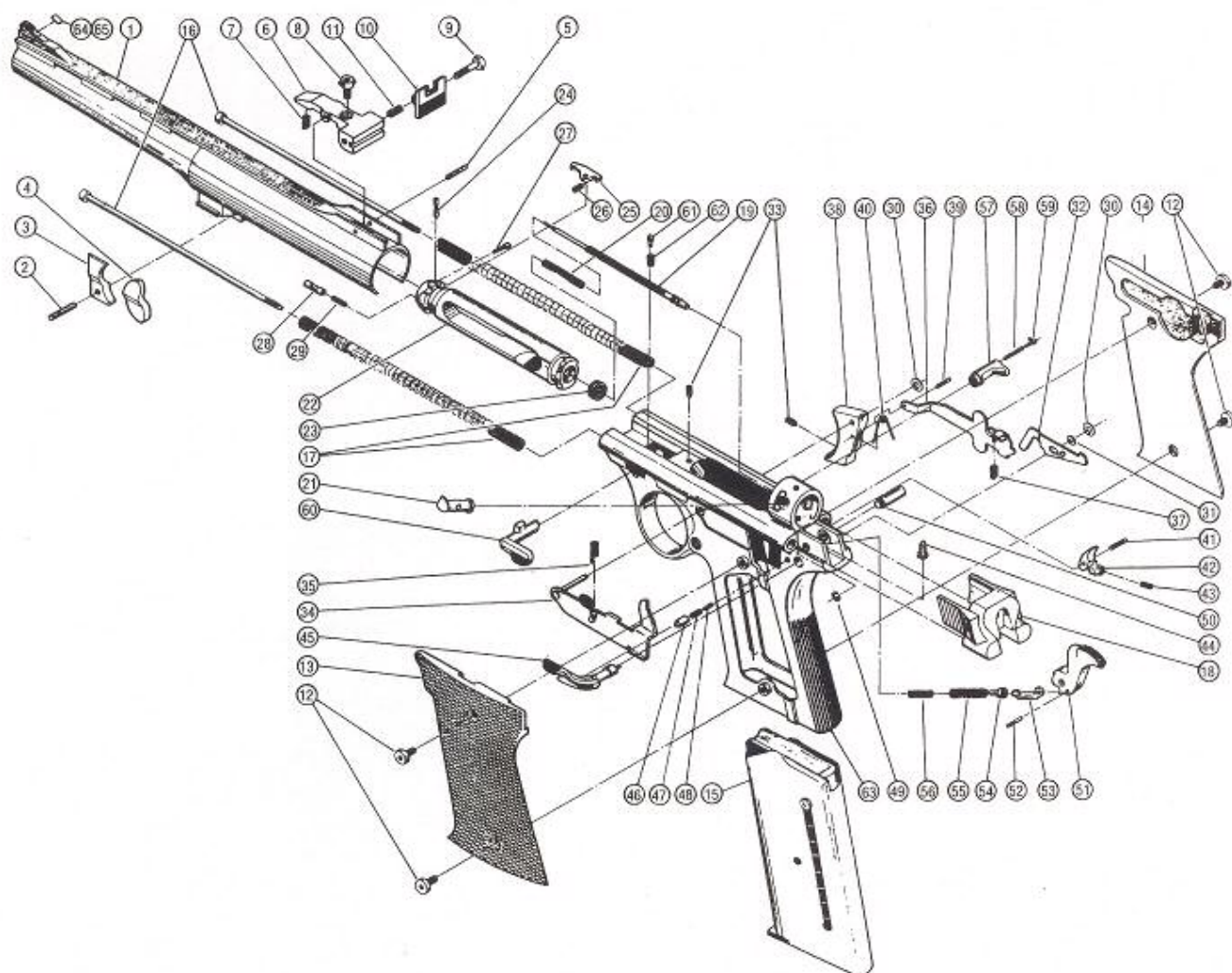

ITEM #	NOMENCLATURE OR DESCRIPTION	ITEM #	NOMENCLATURE OR DESCRIPTION	ITEM #	NOMENCLATURE OR DESCRIPTION
1	BARREL & EXTENSION ASSEMBLY	23	BOLT ROTATION SPRING	45	SAFETY LEVER
2	ACCELERATOR BLOCK PIN	24	EXTRACTOR RETAINING PIN	46	SAFETY LEVER DETENT PLUNGER
3	ACCELERATOR BLOCK	25	EXTRACTOR	47	SAFETY LEVER DETENT SPRING (OUTER)
4	ACCELERATOR	26	EXTRACTOR SPRING	48	SAFETY LEVER DETENT SPRING (INNER)
5	REAR SIGHT PIN	27	EJECTOR RETAINING PIN	49	HAMMER PIN RETAINING RING
6	REAR SIGHT PLATFORM	28	EJECTOR	50	HAMMER PIN
7	REAR SIGHT ELEVATION SPRING	29	EJECTOR SPRING	51	HAMMER
8	ELEVATION ADJUSTMENT SCREW ASSY	30	RETAINING RING	52	HAMMER STRUT PIN
9	WINDAGE ADJUSTMENT SCREW ASSY	31	SAFETY PLATE SPACER	53	HAMMER STRUT
10	REAR SIGHT BLADE	32	SAFETY PLATE	54	HAMMER STRUT GUIDE
11	REAR SIGHT WINDAGE SPRING	33	TRIGGER ADJUSTMENT SCREW	55	HAMMER SPRING (OUTER)
12	GRIP SCREW	34	HOLDOPEN ASSY	56	HAMMER SPRING (INNER)
13	LEFT GRIP	35	HOLDOPEN SPRING	57	MAGAZINE LATCH
14	RIGHT GRIP	36	TRIGGER BAR	58	MAGAZINE LATCH SPRING
15	MAGAZINE ASSY	37	TRIGGER BAR SPRING	59	MAGAZINE LATCH RETAINER
16	RECOIL ROD	38	TRIGGER	60	BARREL LATCH
17	RECOIL SPRING	39	TRIGGER BAR PIN	61	BARREL LATCH DETENT PLUNGER
18	COCKING PIECE	40	TRIGGER SPRING	62	BARREL LATCH DETENT SPRING
19	FIRING PIN	41	SEAR PIN	63	FRAME
20	FIRING PIN SPRING	42	SEAR	64	SIGHT INSERT MATERIAL (RED)
21	BOLT ROTATION PIN	43	SEAR SPRING	65	SIGHT INSERT MATERIAL (YELLOW)
22	BOLT	44	BOLT SAFETY TAPPET		